



Space Selection Essentials & Important Dates

August 14, 2024



AGENDA



- Space Selection Communications
- Understanding/Navigating the Floor Plan
- How to Prepare
- Space Selection Day
- Rules & Regulations
- Critical Dates
- Q&A

SPACE SELECTION COMMUNICATIONS



- Email sent August 5
 - Space selection date and time
 - Zoom link to join during your appointment time
 - www.nafem.org
 - Priority Points
 - Make sure to [RSVP](#) to confirm company participation
- Email sent week of September 2
 - Exhibit space confirmation

UNDERSTANDING/ NAVIGATING THE FLOORPLAN



- [2025 Floor Plan](#)
- Georgia World Congress Center (GWCC) – Halls B/C
- Entrances
- Hotel locations
- Registration/shuttle drop off
- Food & Beverage
- NAFEM Booth
- Lounges (3)
- What's Hot! What's Cool!
- U.S Culinary Open
- @Centerstage
- Clean-Up Areas

UNDERSTANDING/ NAVIGATING THE FLOORPLAN



- [2025 Floor Plan](#)
- Booth sizes
- Service aisles
- Combining booths for islands and peninsulas
- No freight aisle
- **IMPORTANT RULE:** Booth width must be less than or equal to booth length for any booths larger than 600 sq. ft.
- Utilities

HOW TO PREPARE



- Practice navigating the [floor plan](#) ahead of time
- Check availability the day before and hour before your selection
- Make a list of your top 3 choices, 15 minutes prior to your selection time

Note: Keep an eye on the floor plan **after** you select your space. NAFEM will not notify you if a competitor selects near you. We are happy to move you if you no longer like your booth space.

SPACE SELECTION DAY



1. Click on the zoom link to join our waiting room.
2. Our exhibits team will admit you based on your appointment time and will assign you to one of our team members to discuss and select your space.
3. Space confirmed and reflected on website within 1-2 minutes.
4. Email confirmation/invoice sent the week of Sept. 2.

Note: You may be in the Zoom waiting room for a few minutes if our team is finishing up an appointment with another company.

RULES & REGULATIONS



- [2025 Rules and Regulations](#)
- Section 4: Assignment of Space
- Most common rule violations
 - Inline
 - Peninsula
 - Island
- [Review Rules & Regulations Video](#)

RULES & REGULATIONS – INLINE BOOTHS

- Inline Booth

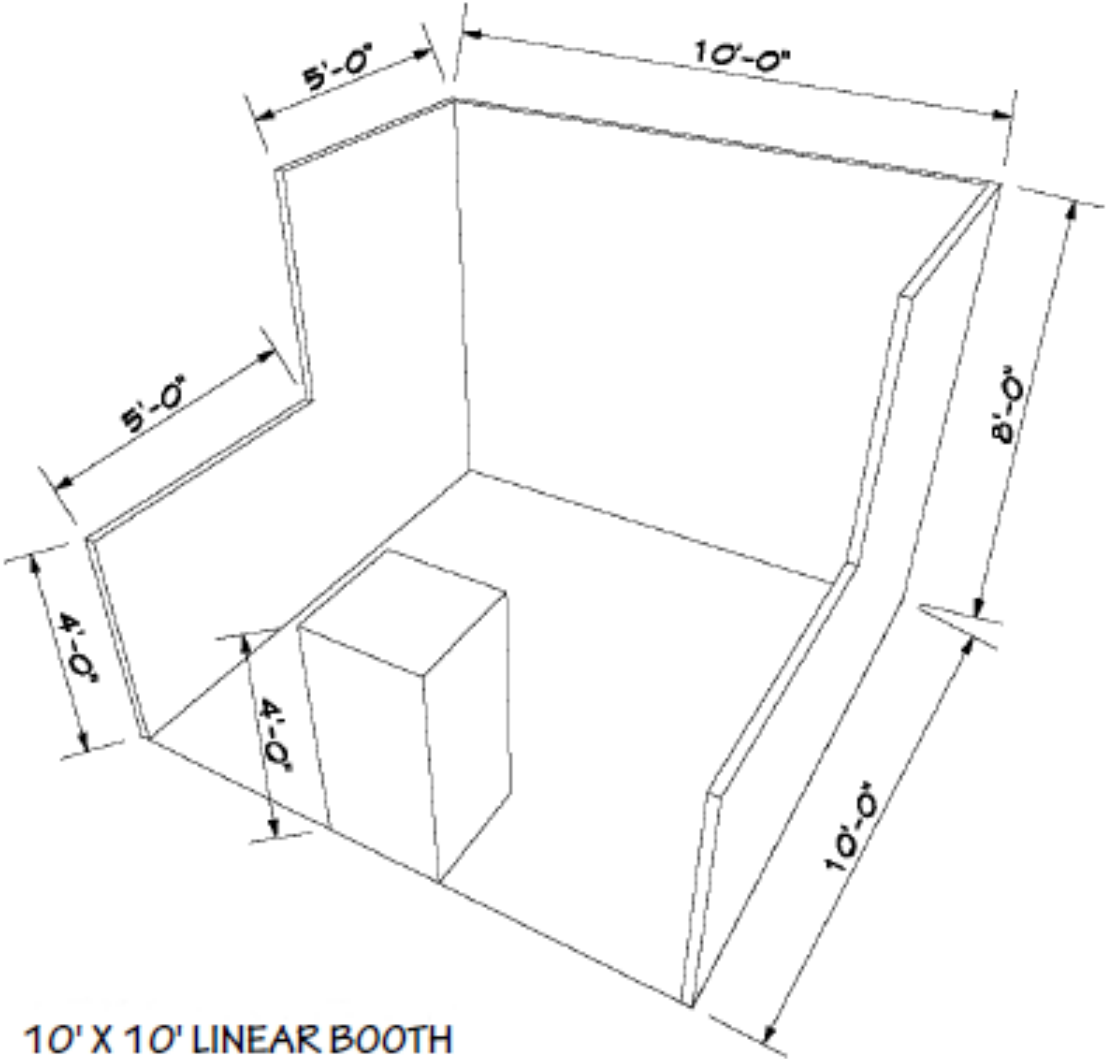

10' X 10' LINEAR BOOTH

RULES & REGULATIONS – INLINE BOOTHS

- Inline Booths
 - NAFEM requires exhibitors who manufacture walk-in coolers, refrigerators and freezers to purchase a booth with a depth of 15' (4.57m).

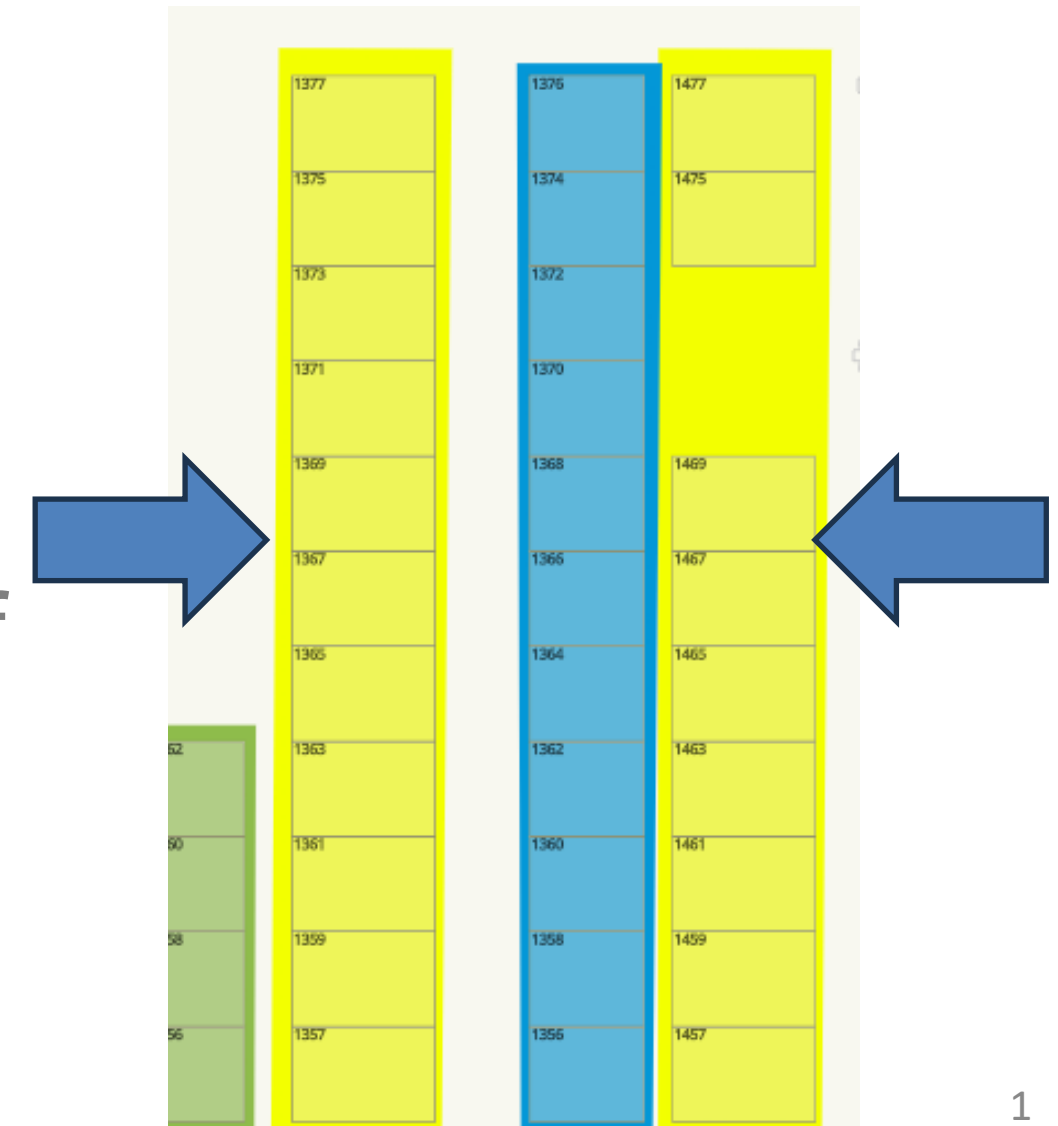

RULES & REGULATIONS – PENINSULA BOOTH

- Peninsula Booth

Hanging signs are permitted to a maximum height of 20' to the top of the sign

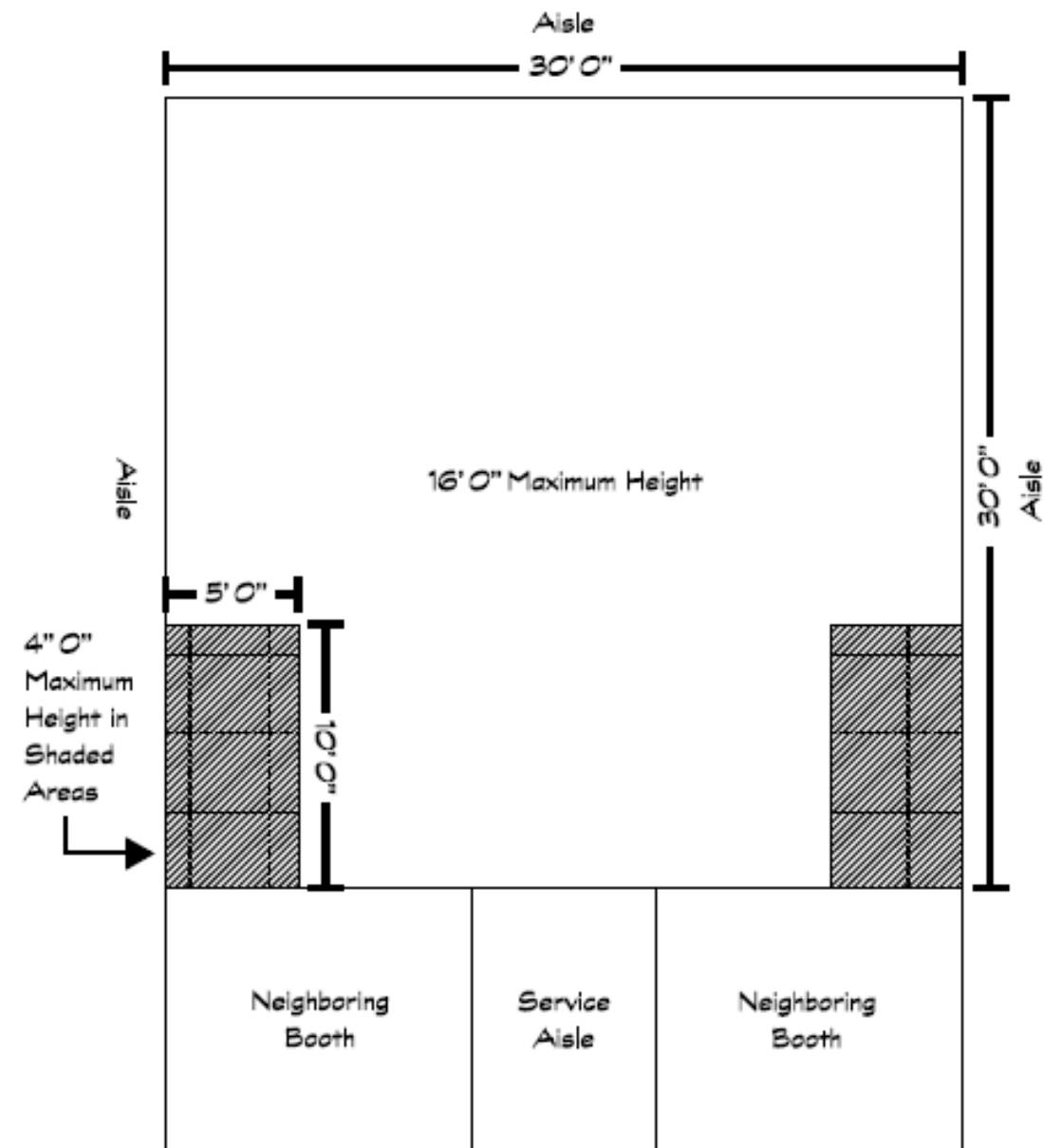

RULES & REGULATIONS – ISLAND BOOTH

- Island Booth

Hanging signs are permitted to a maximum height of 20' to the top of the sign

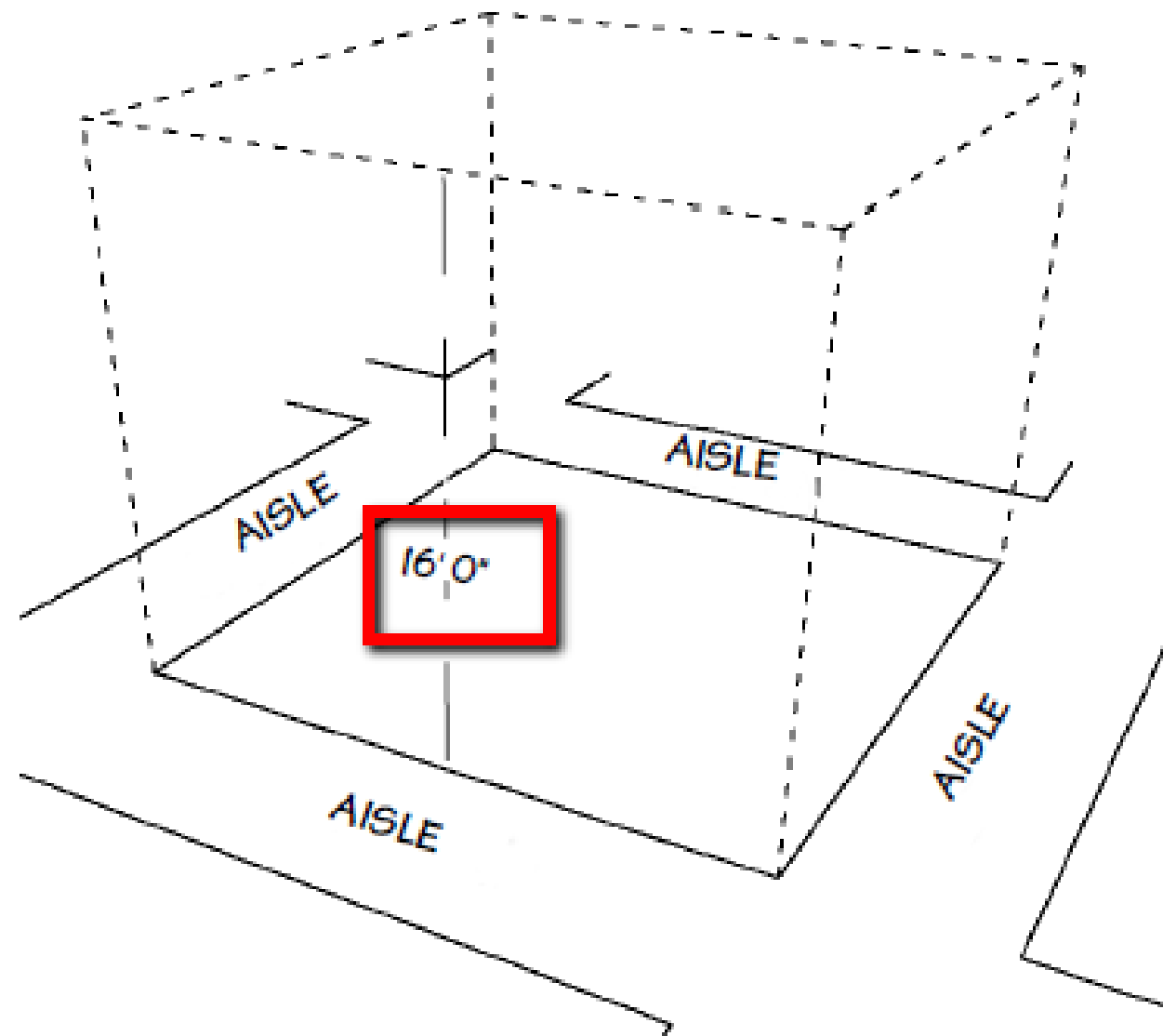

BOOTH DIAGRAMS



- Prevent an onsite headache -- let us check your floor plan
- Detailed floor plan with dimensions required to submit to info@thenafemshow.org by Nov. 8 for:
 - Manufacturers with walk-in coolers, refrigerators and freezers
 - Peninsulas
 - Islands
 - Companies with written booth violation notices from 2023

IMPORTANT DATES



- Aug. 19 - 21
 - Online space selection for companies with 200+ points
- Aug. 26 - 29
 - Online space selection for companies with less than 200 points
 - Associate Members
 - Non-Members
 - Companies that submitted their 50% payment after July 26 deadline
- Sept. 18
 - Exhibit Resource Center available
 - Exhibitor Registration and Exhibitor Services Manual accessible online

IMPORTANT DATES



- Nov. 1
 - Final 50% payment due
 - NAFEM keeps 25% of total booth fee for all space reductions or cancellations occurring between space selection and Nov. 1
 - After Nov. 1, full balance due on any reduced or cancelled booths

IMPORTANT DATES



- Nov. 8
 - Detailed floor plans due for exhibitors occupying an island, split island, peninsula, or modified peninsula booth; manufacturers of walk-in coolers, refrigerators and/or freezers; or those with written booth violation notices from 2023
 - Hanging signs are permitted to a maximum height of 20' to the top of the sign.
- Ongoing
 - [Exhibitor education webinar & video series](#)
 - <https://www.thenafemshow.org/>

The
NAFEM
Show® | **25**
FEBRUARY 26-28 • ATLANTA



Q&A

info@thenafemshow.org

The
NAFEM
Show® | **25**
FEBRUARY 26-28 • ATLANTA



THANK YOU

The
 **NAFEM** | **25**
Show.®

FEBRUARY 26-28 • ATLANTA